

Megaswitch S

You can use Megaswitch S for the following switching positions:

SSS2

This is the new Stratocaster standard switching system which was introduced in the mid-1970s. Many guitarists at that time realized that quite interesting sounds were obtainable in the spaces between the existing switching systems so-to-speak, where two neighboring pickups operate simultaneously. As a result, the three-position switch was replaced by a new five-position version. The tone controls were assigned as they had always been, i.e they remained unchanged. For this reason, both function in position 4. The Megaswitch S is ideal for this application. In principle, the wiring is the same as for the SSS1. To enable buzz-free playing in positions 2 and 4 at least, the middle pickup must be magnetically reverse-poled and wound in the opposite direction similar to the two outer pickups. Here too, it is possible to assign tone controls in a range of ways.

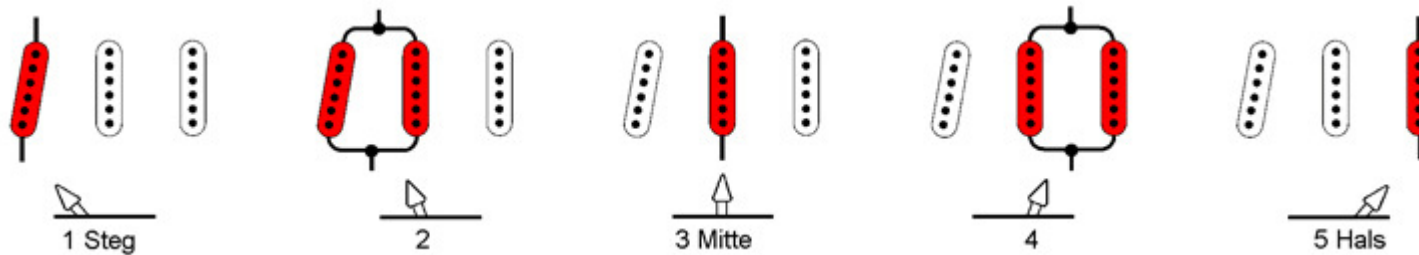

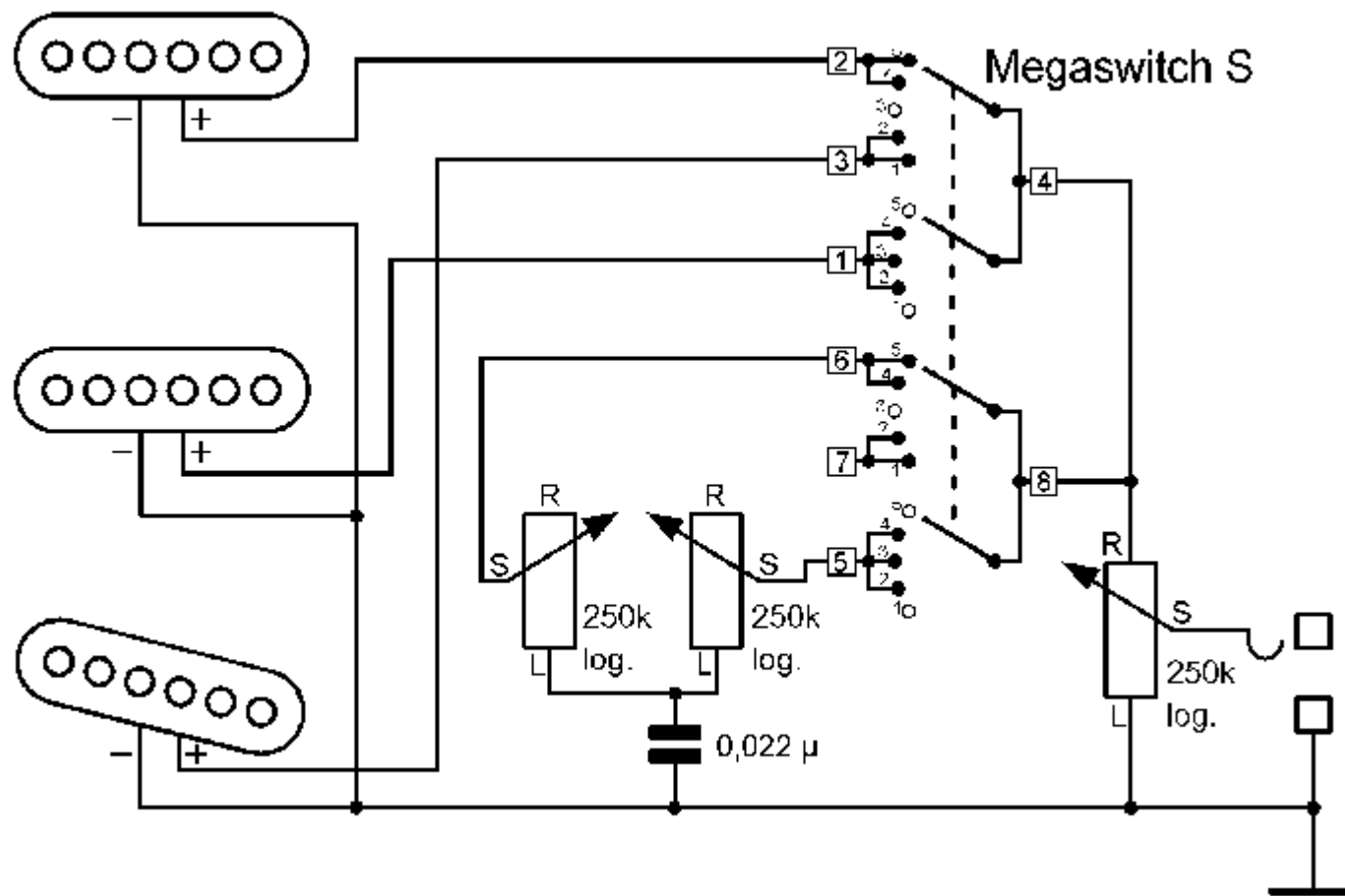

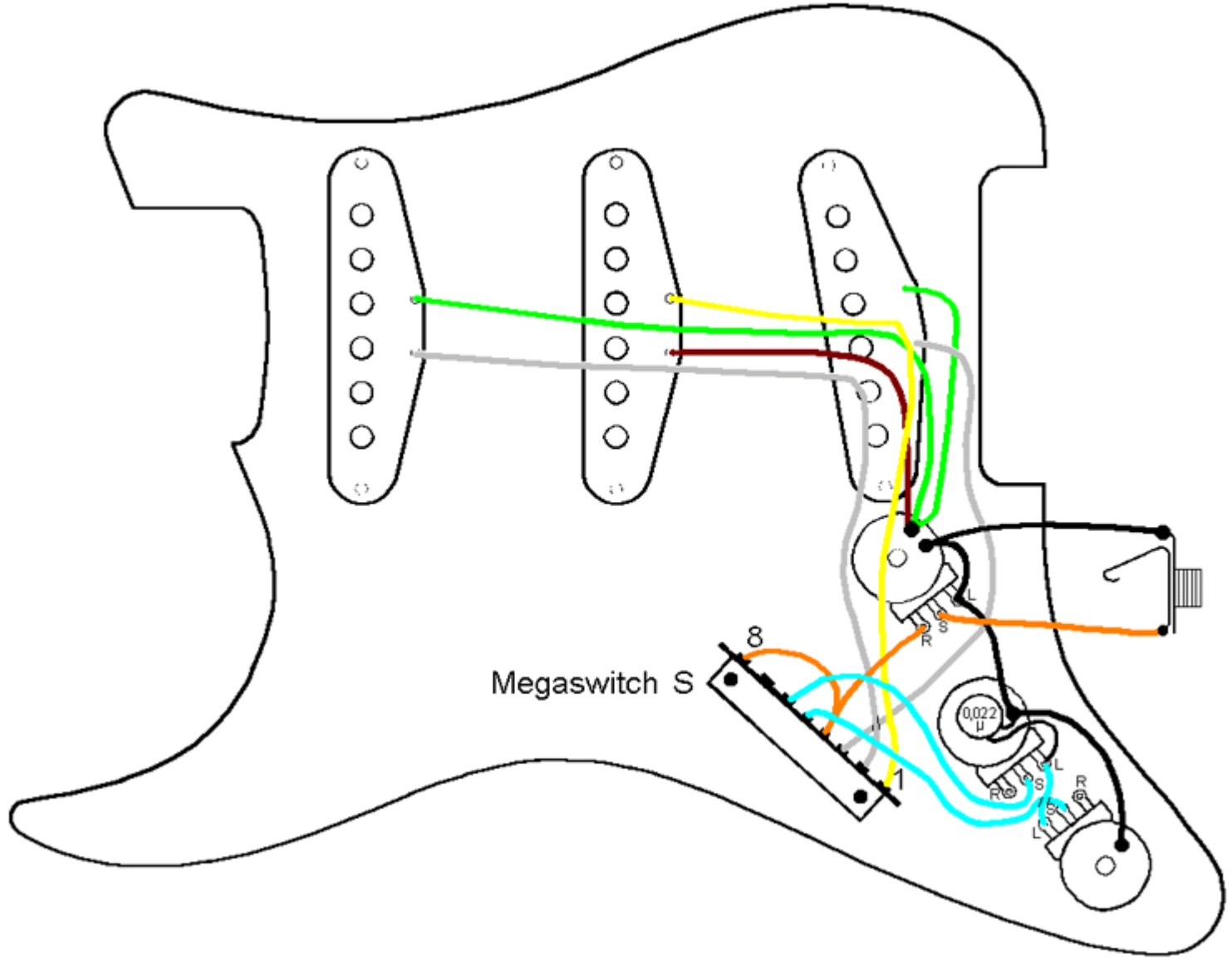

Megaswitch S

8

1

0.022
μ

R

S

L

R

S

L

R

S

L

HSS1

On some Stratocaster versions the bridge single coil is replaced by a Humbucker. In switching position 1 this creates a fuller sound with less brightness in the high end, more warmth in the mids and louder basses. erhält man damit einen volleren Sound mit weniger grellen Höhen und mehr warmen Mitten und lauterem Bässen. A Megaswitch S is used here. If a buzz-free sound is required in position 4, both single coils must have opposing magnetic polarity.

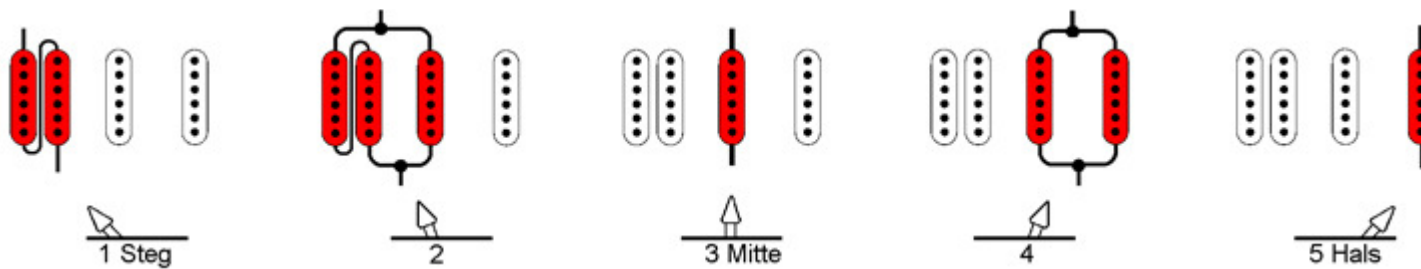

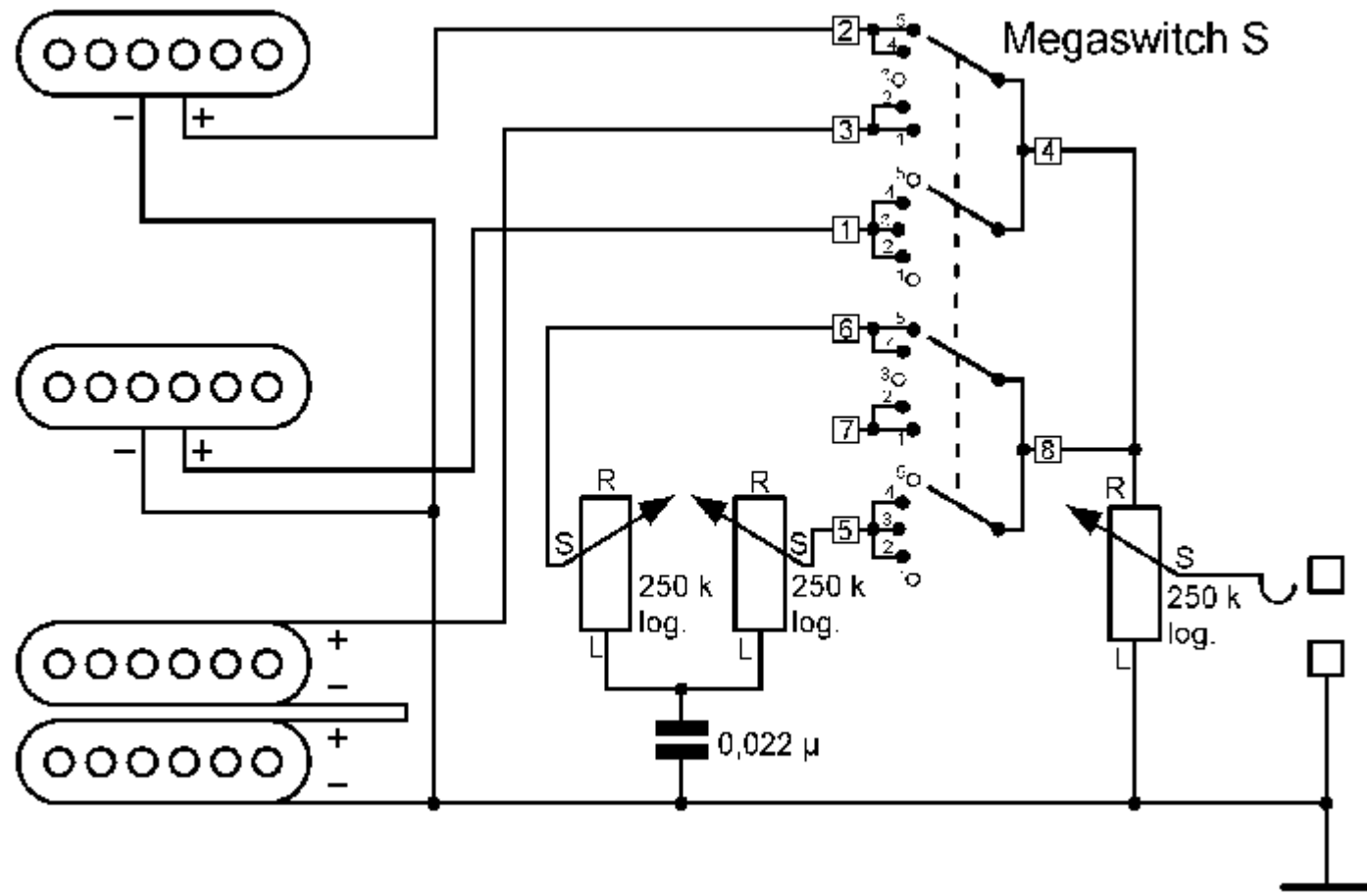

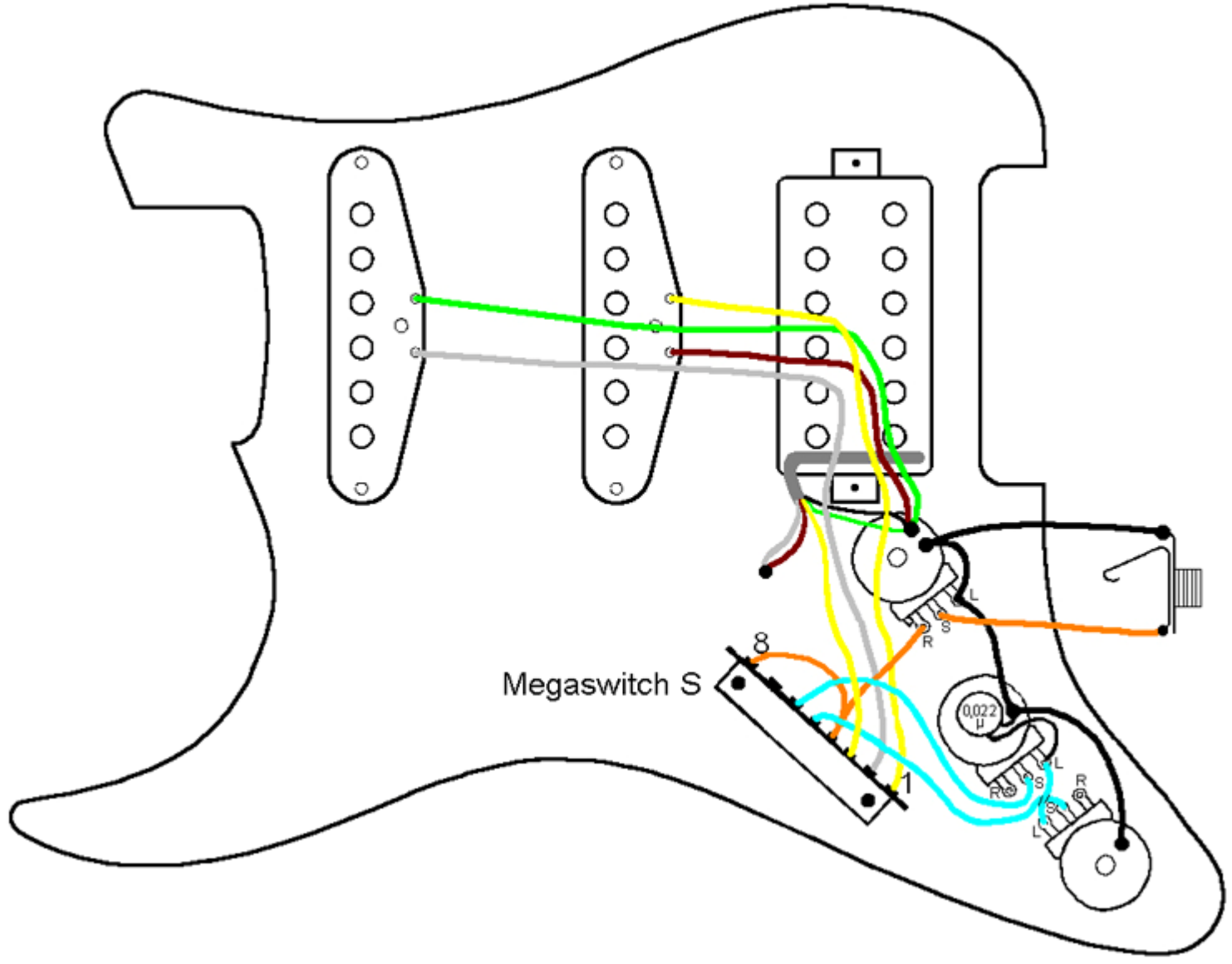

HSS2

This is a variation on the HSS1 switching system. In position 2, the Humbucker is split; the outer coil remains in operating mode and the inner coil is short-circuited. This also works with the Megaswitch S. If a buzz-free sound is required in positions 2 and 4, the following magnetic polarity (from the bridge to the neck) is necessary: NS-S-N or SN-N-S.

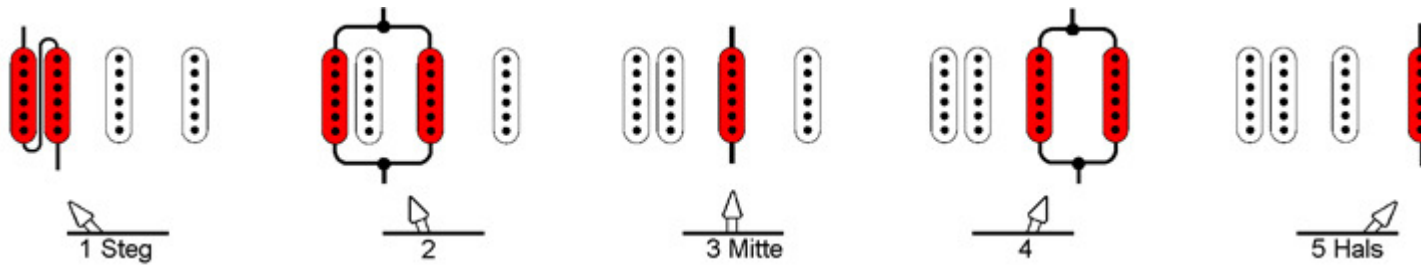

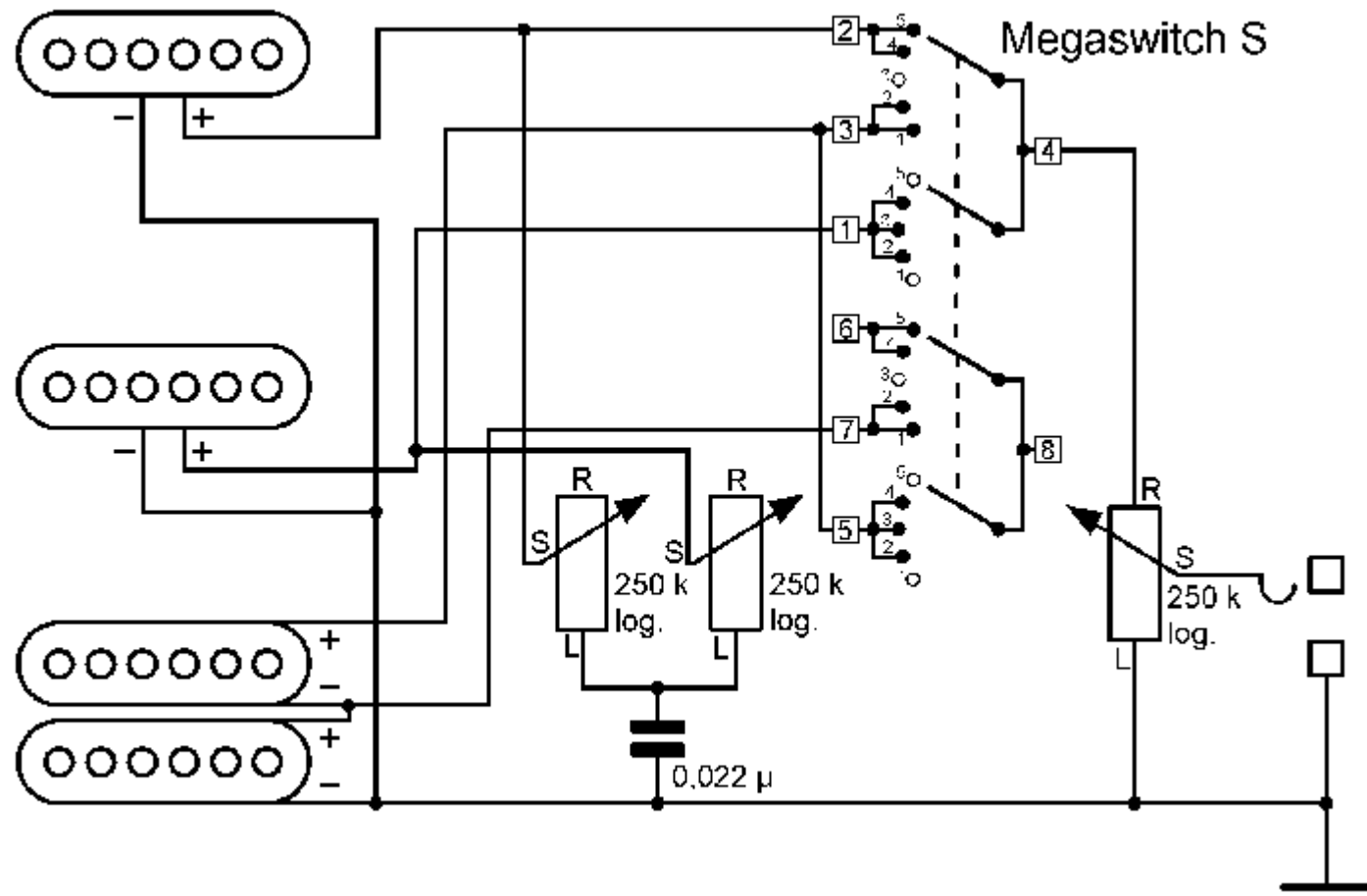

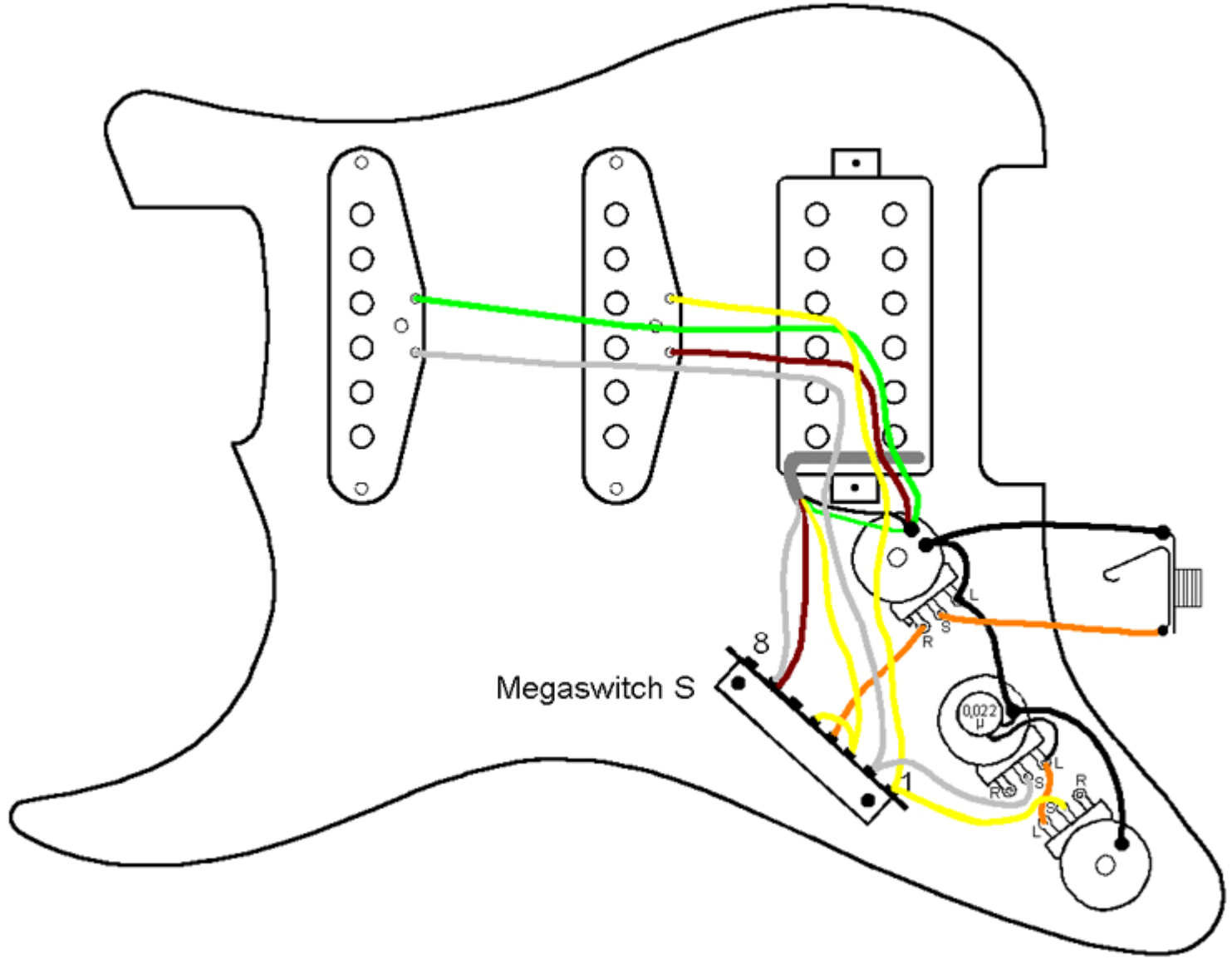

HSS3

This is a slight variation on the HSS2 switching system. Similar to the HSS2, the Humbucker is split in position 2. Here, the inner coil remains in operating mode. The coil closest to the bridge is short-circuited onto the earth/ground. This also functions with the Megaswitch S. If a buzz-free sound is required in positions 2 and 4, the following magnetic polarity (from the bridge to the neck) is required: NS-N-S or SN-S-N.

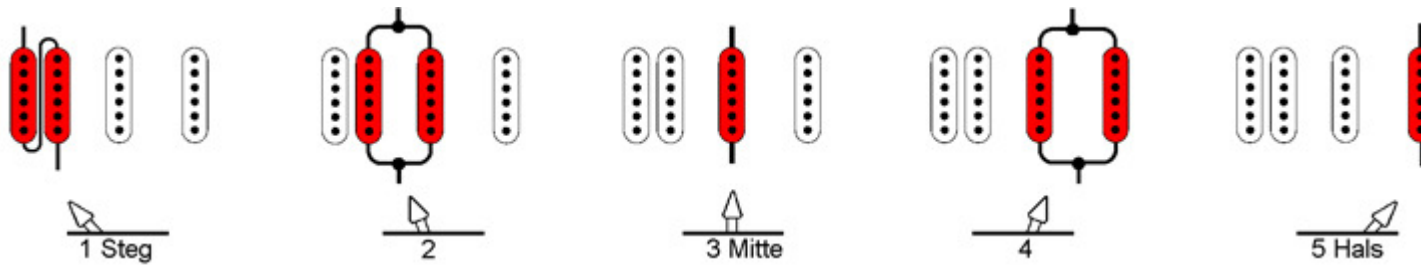

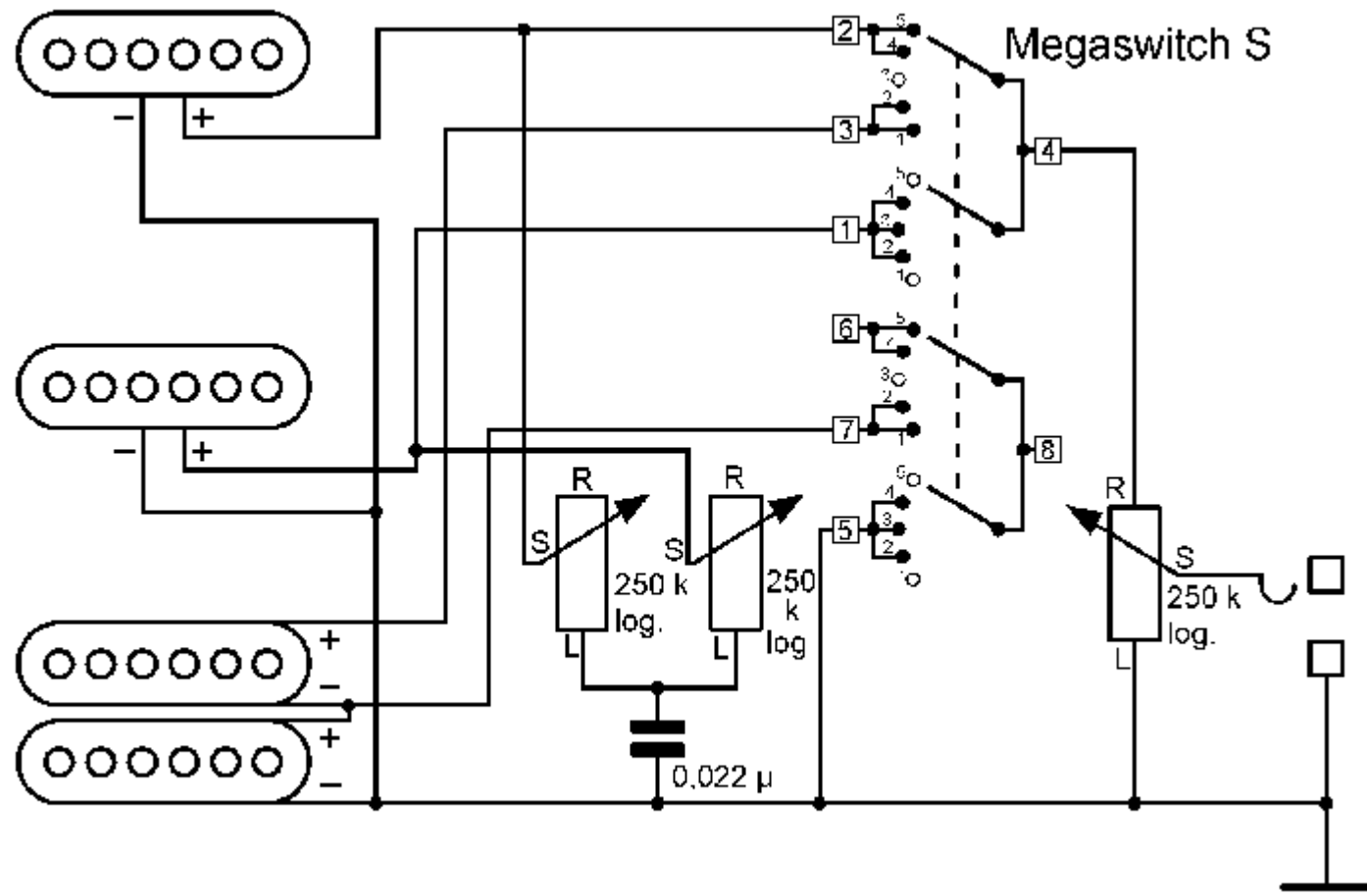

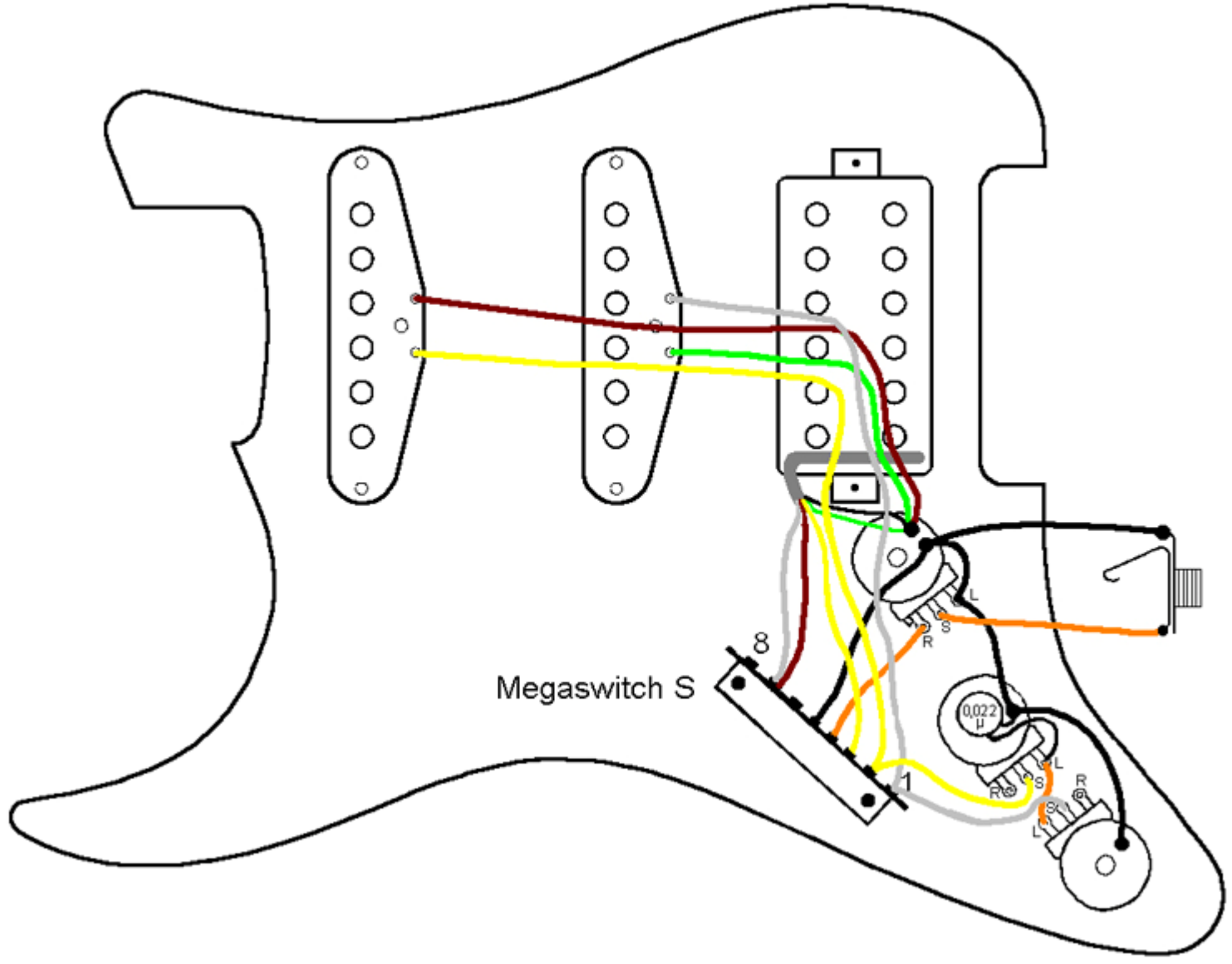

HSH1

This is the simplest switching system for guitars with two Humbuckers and a single coil located between them. Here, the Humbuckers are not split and the switching functions are as usual. The Megaswitch S is ideal for this application. A version with two tone controls is illustrated. If only one is to be used, the wiper should be connected to connection 4 of the Megaswitch.

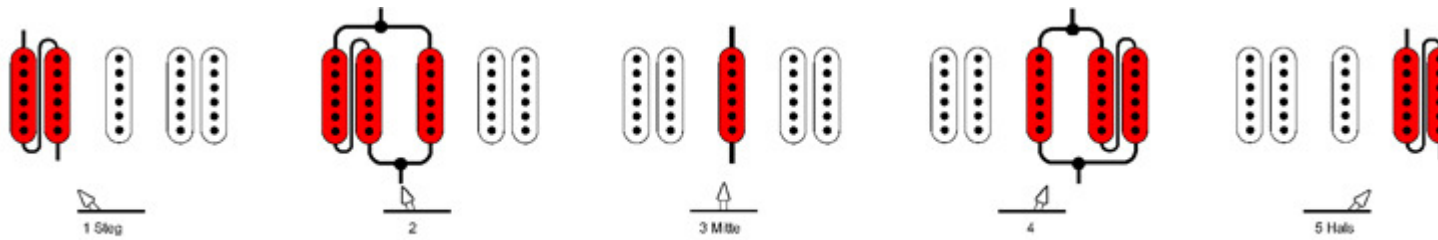

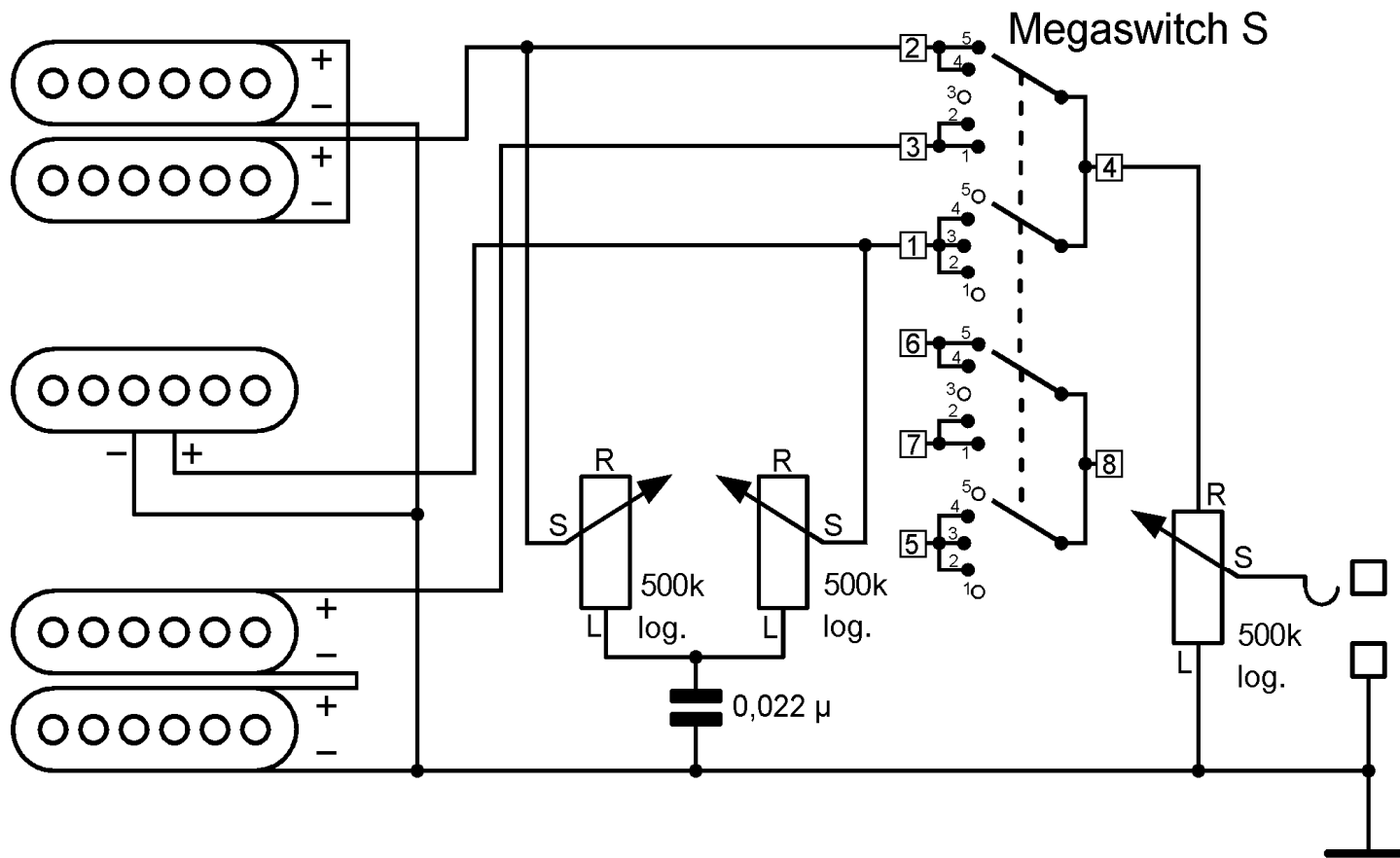

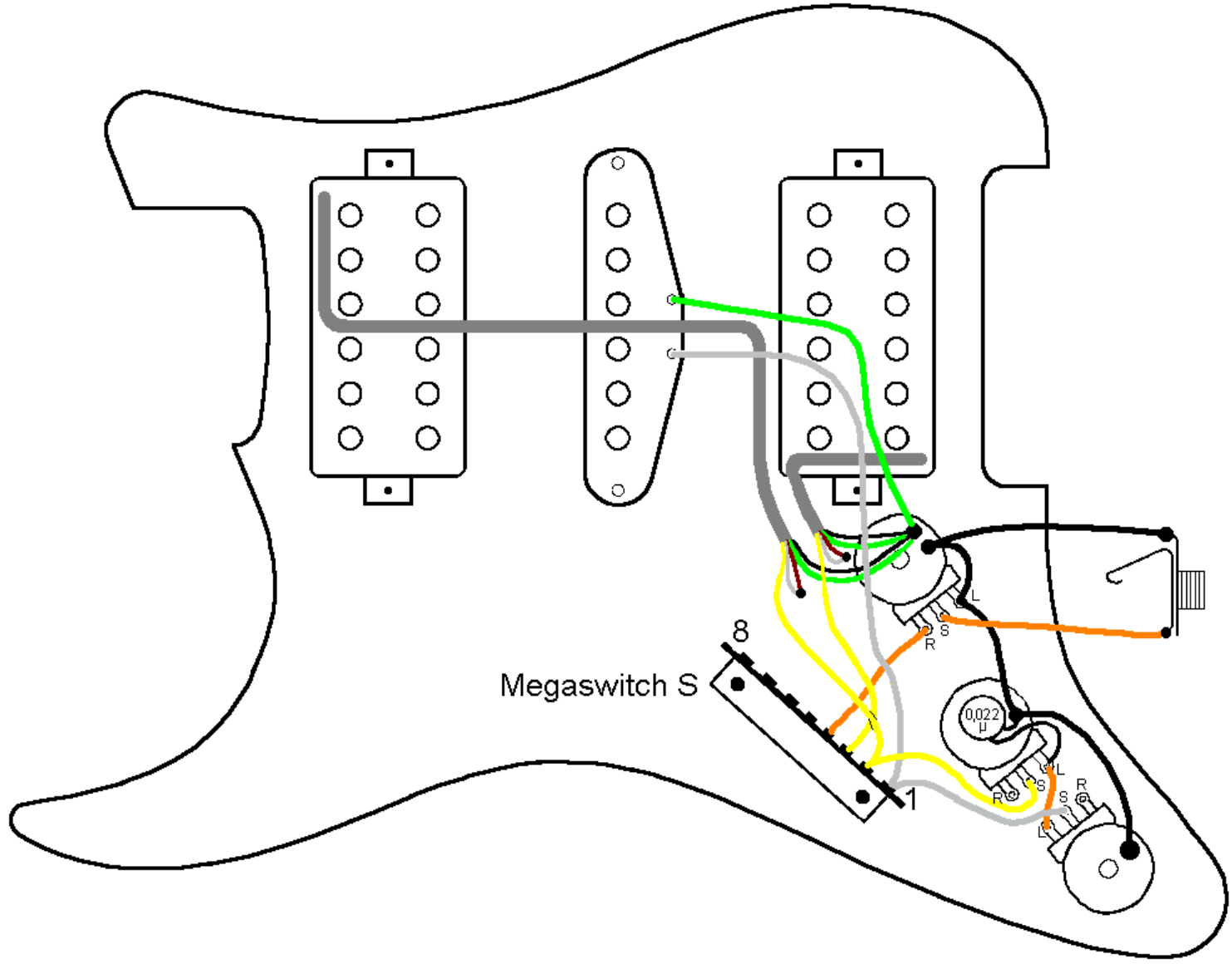

HSH2

This switching system is for guitars with 2 Humbuckers and a single coil between them. The Humbuckers are split in positions 2 and 4, while the inner coils remain active. The outer coils are short-circuited. In the event that a buzz-free sound is required in positions 1, 2, 4 and 5, the following magnetic polarity is required: NS-N-SN or SN-S-NS. The Megaswitch S is ideal for this application. A version with two tone controls is illustrated here. If only one tone control is used, its wiper should be connected to connection 4 of the Megaswitch.

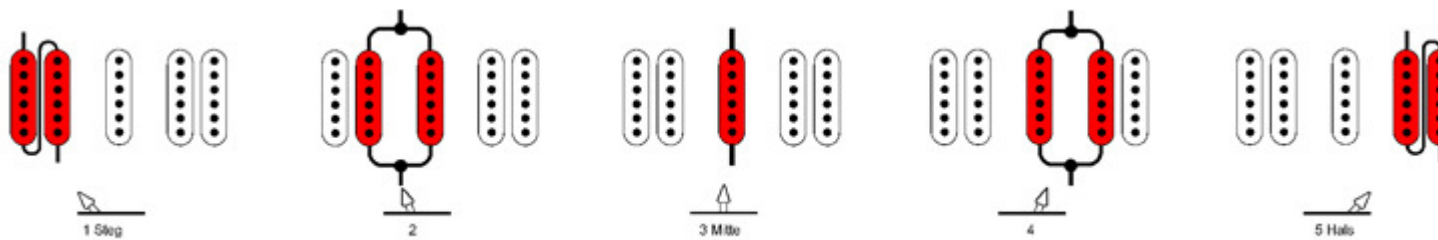

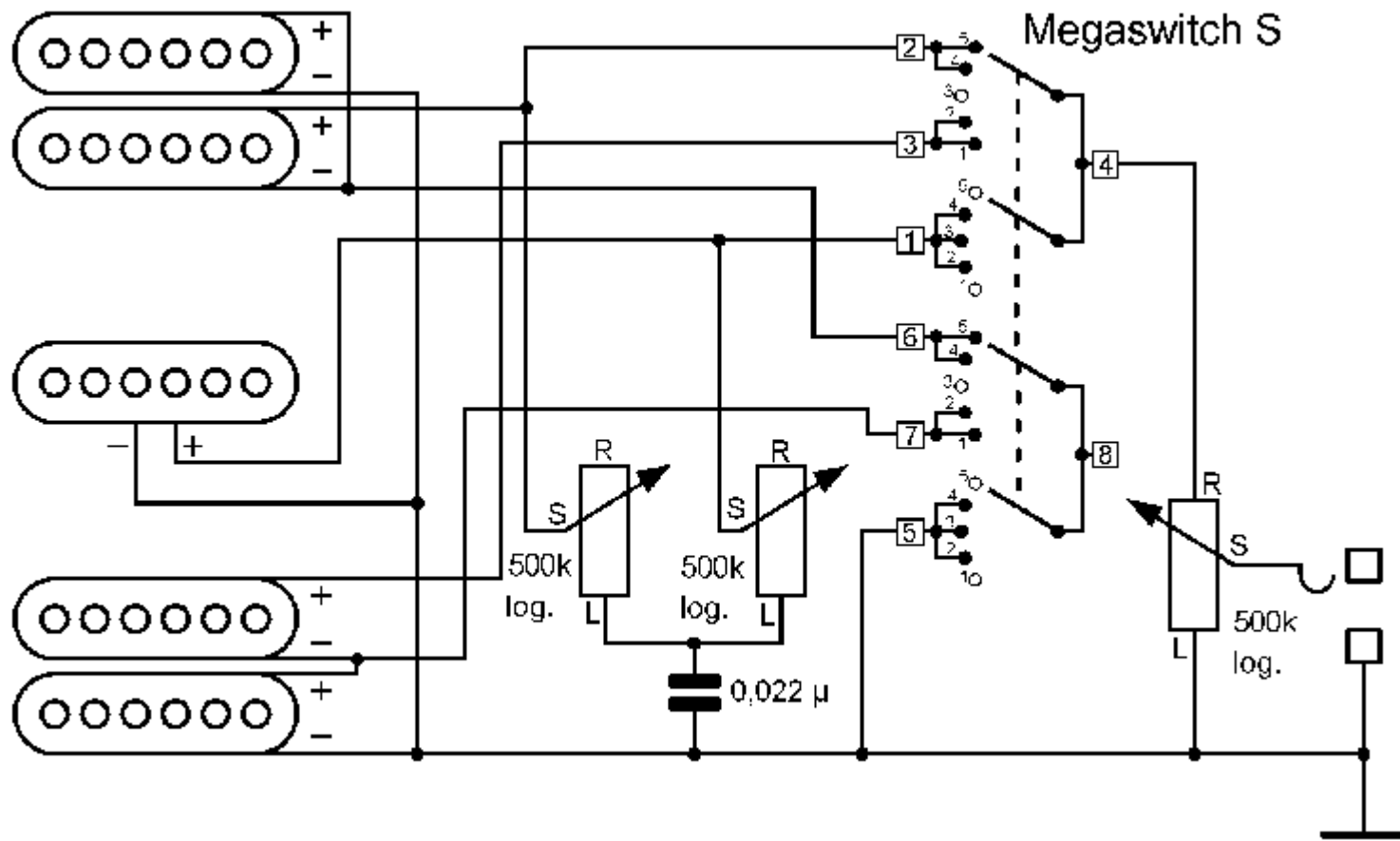

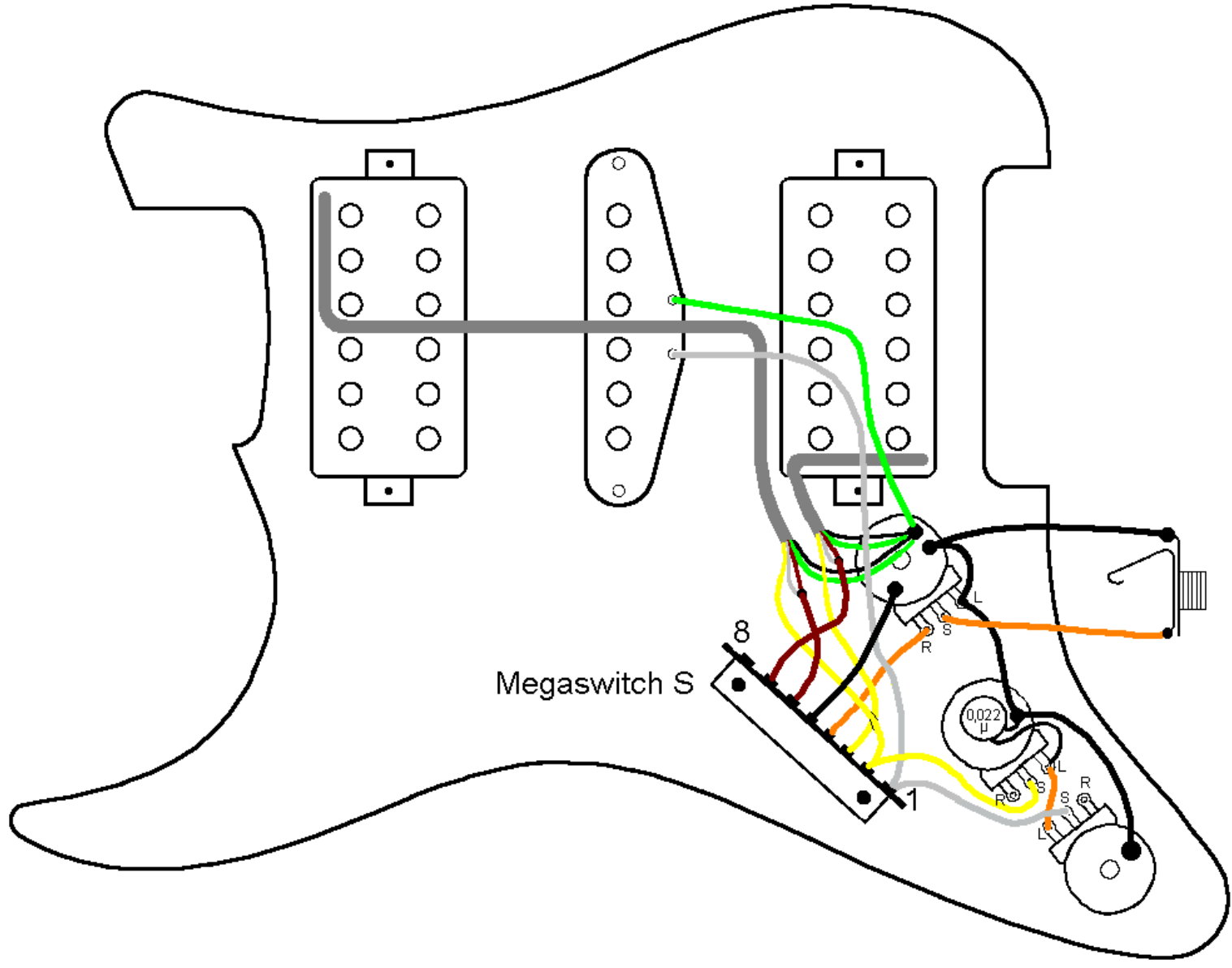

HSH3

This switching system is for guitars with 2 Humbuckers and a single coil between them. The Humbuckers are split in positions 2 and 4. Contrary to the HSH2, the outer coils remain active and the inner coils are short-circuited. In the event that a buzz-free sound is required in positions 1, 2, 4 and 5, the following magnetic polarity is required: NS-S-SN or SN-N-NS. The Megaswitch S is ideal for this application.

The outer coils are short-circuited. In the event that a buzz-free sound is required in positions 1, 2, 4 and 5, the following magnetic polarity is required: NS-N-SN or SN-S-NS. The Megaswitch S is ideal for this application. A version with two tone controls is illustrated here. If only one tone control is used, its wiper should be connected to connection 4 of the Megaswitch.

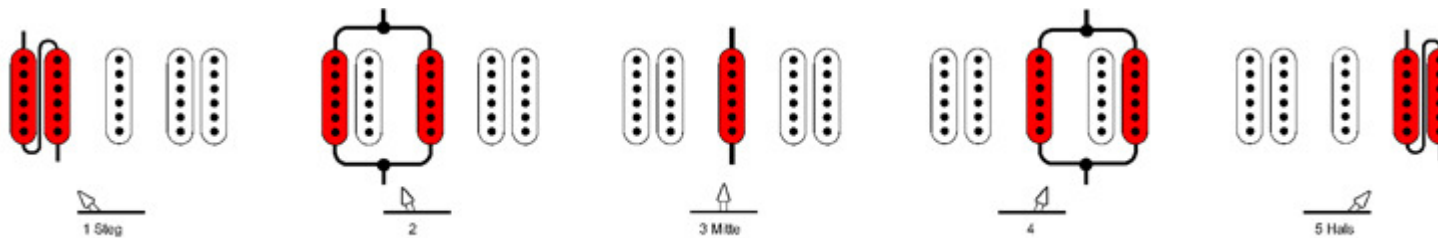

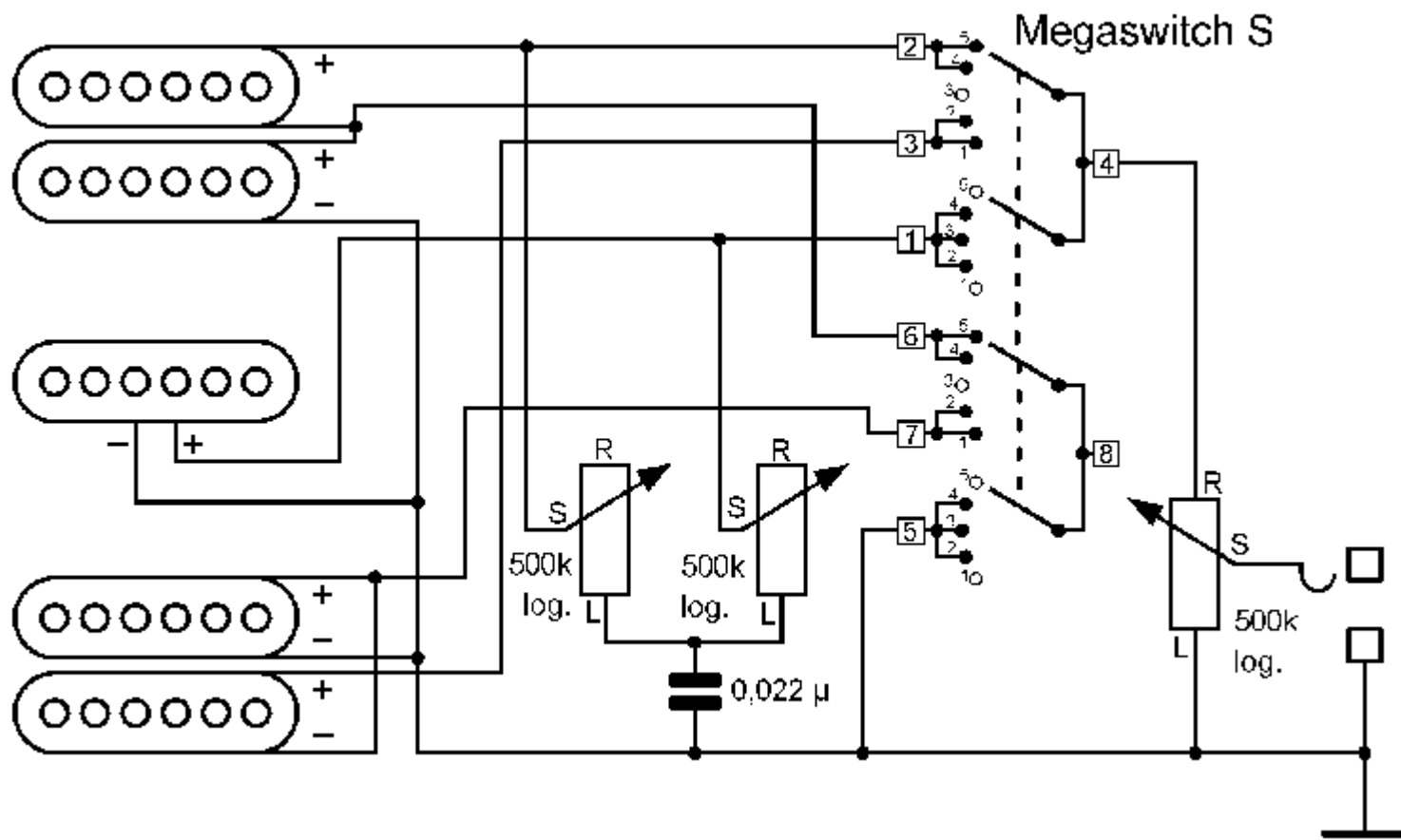

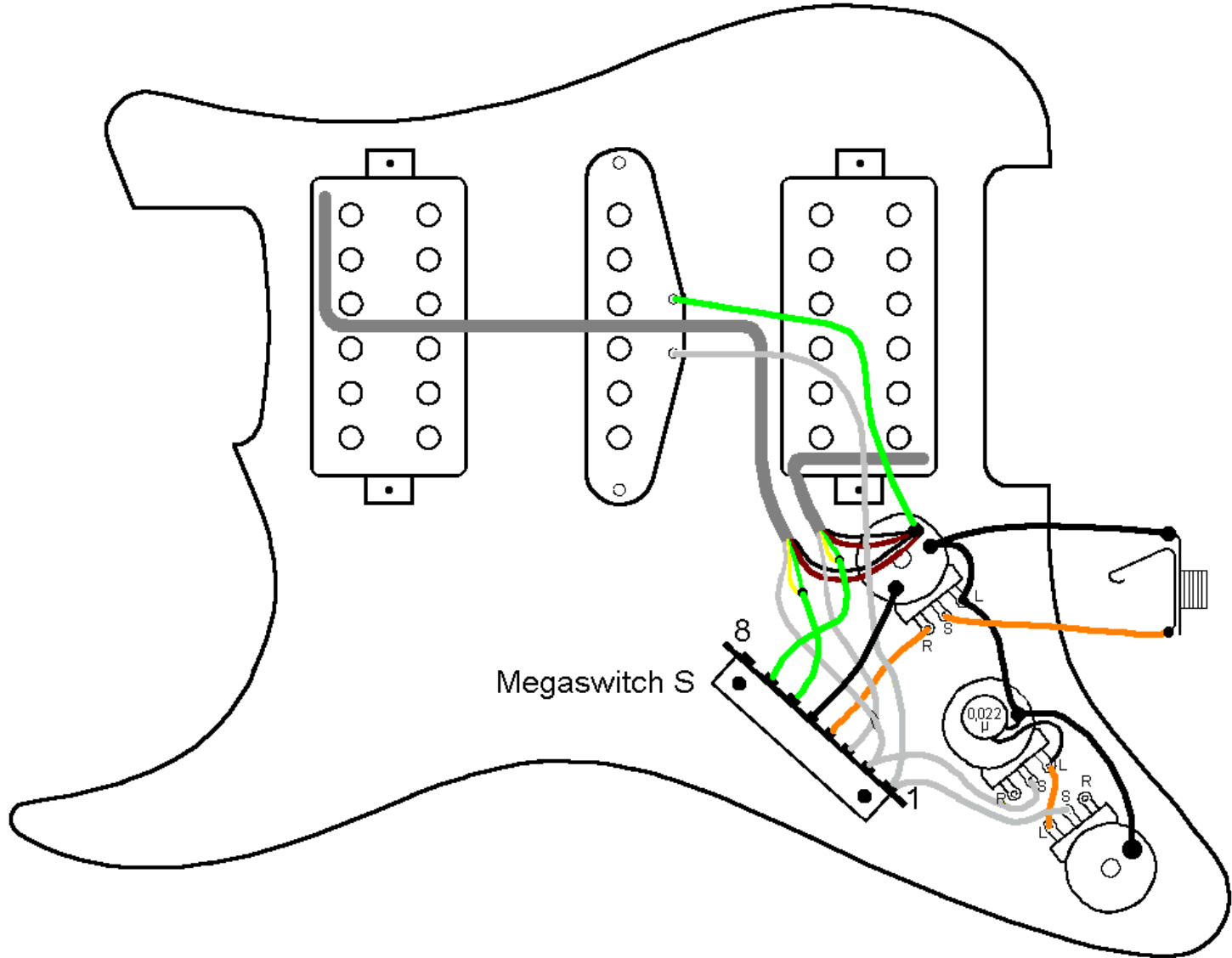

Megaswitch S

8

1

L

R

S

0.022
μ

L

R

S

L

R

S

L

R

S

L

R

S

L

R

S

L

R

S

L

R

S

L

R

S

L

R

S

L

R

S

L

R

S

L

R

S

L

R

S

L

R

S

L

R

S

L

R

S

L

R

S

L

R

S

L

R

S

L

R

S

